

• Basic Amateur Radio

The Ups and Downs of Towers

Thinking about erecting a tower? Confused by the wide variety of types and accessories? Here are some basic facts that may help you decide.

By Peter O'Dell,* KB1N

On a calm morning after a violent storm, a friend walked out of his house to check his antenna farm. In the past he had lost an occasional dipole leg, but nothing more serious. This morning it was different: He looked up to find that his tower now extended vertically 60 feet (18 m) and horizontally 30 feet (9 m) from the top of the vertical portion. Although he may not have considered himself lucky, he was. The only real damage was to two sections of the tower. Cleanup consisted of removing everything above the fifth section. Oh, it wasn't easy, but he managed to do it safely.

At the time, he may not have thought so, but things could have been a lot worse. I've heard a story of an Amateur Radio operator who lost his life when his tower crashed through the roof of his house, causing the 20-meter reflector to impale him in his bed as he slept. I have no idea whether this really happened or not, but it certainly isn't out of the realm of possibility. I say my friend was lucky, not because he escaped unharmed, but because he had tempted fate for years and still came away unscathed. How had he tempted fate? His choice of tower was light-duty "TV tower." Instead of obtaining the manufacturer's recommended procedures for installation, he merely dug a small hole, filled it with two bags of hand-mixed concrete and set the bottom section of the tower in the hole. He installed large (projected surface area) antennas that far exceeded the maximum ratings that the tower could safely handle. His guy-wire choice, the small type normally used for roof-mount TV antenna installations, was

just as overly optimistic. He was indeed lucky that things had lasted this long without major damage to property (or people).

Destructive Forces

Probably the most destructive force that your tower will have to withstand is wind. It is difficult to imagine the magnitude of force that wind can have as it pushes against a tower. The force is related to the projected surface area and the square of the velocity of the wind as it moves past the tower. Much more rigorous discussions of wind loading have appeared in Amateur Radio literature and

are suggested for those interested in a more in-depth approach to the topic.^{1,2}

Towers must be built to withstand such forces. The Electronic Industries Association (EIA) has set forth guidelines and standards for antenna structures.³ Based on meteorological data collected over the years, the EIA standards are more stringent for various areas of the country, depending on the highest velocity of wind that can be expected. Fig. 1 depicts these areas graphically. Consult the manufacturer's installation instructions to determine the erection procedures

*Notes appear on page 39.

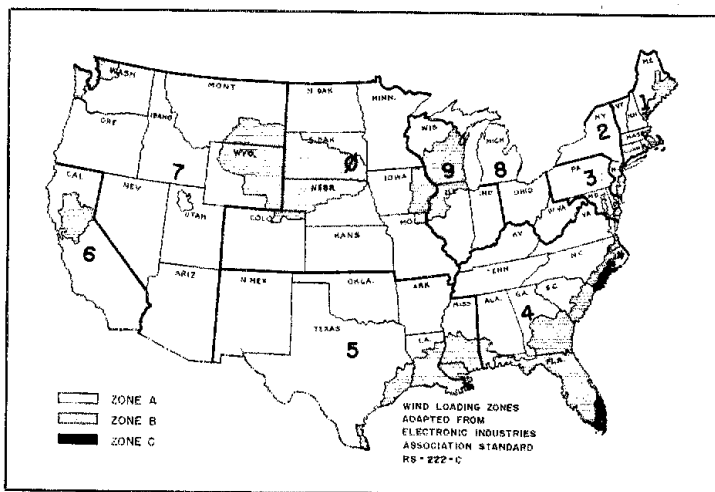

Fig. 1 — Wind-zone map of the continental United States. Structures under 300 feet (91 m) high should be built to withstand winds up to 87 miles per hour (140 km/hr) for zone A; up to 100 miles per hour (161 km/hr) for zone B; and 112 miles per hour (180 km/hr) for zone C. If you are unable to determine which zone you live in because of the limited resolution of this map, you should consult the breakdown by counties in EIA RS-222-C (see Note 3).

*Basic Radio Editor

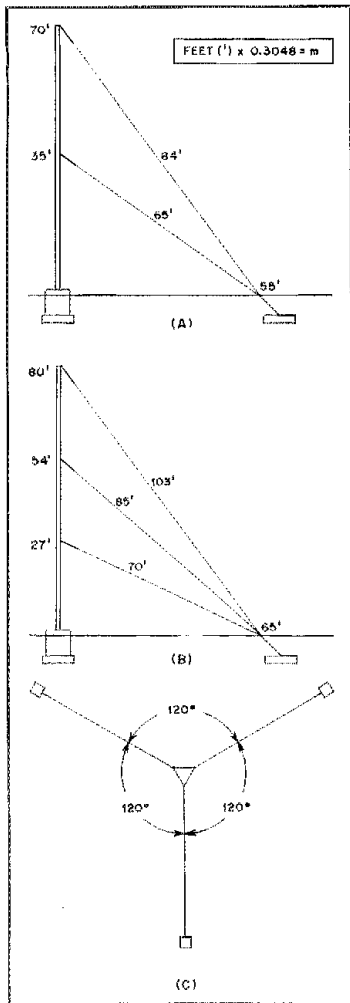

Fig. 2 — Diagram depicting proper method of installation of a typical guyed tower.

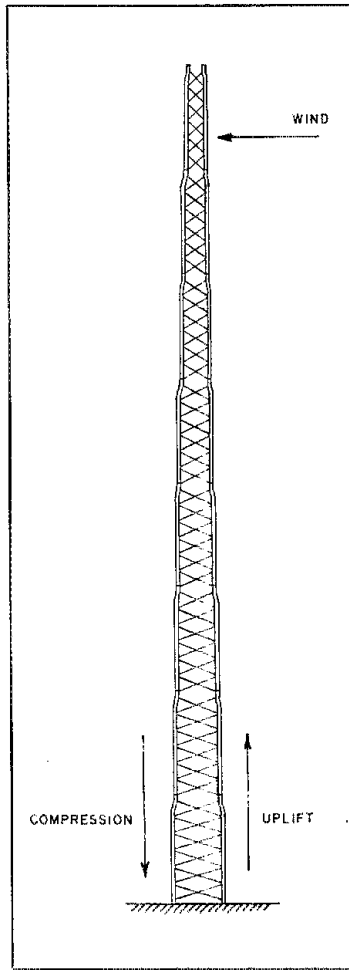

Fig. 3 — Diagram of typical free-standing (unguyed) tower. Arrows indicate the directions of the forces acting upon the structure. See text for discussion.

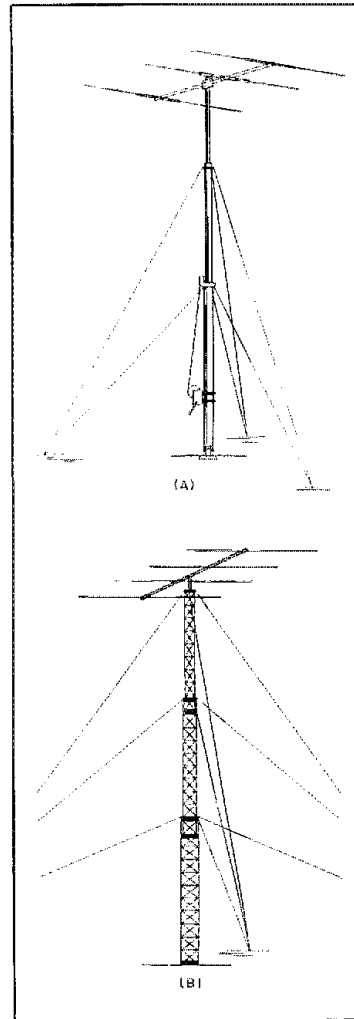

Fig. 4 — Two examples of "crank-up" towers.

for your tower at your particular location. If you are not sure which zone your location is in, you may want to go directly to the EIA pamphlet; it breaks the zones down by county.

Most tower manufacturers specify their products on a "maximum square feet" basis. (In countries using the metric system of measurement, the ratings will be in square meters.) This statistic tells you how many square feet of antenna (projected surface area) you may safely place atop your tower. Most antenna manufacturers provide the square footage of their antennas. If you overload your tower, you run the risk of having it damaged or destroyed in a heavy windstorm. Several manufacturers and dealers have told me

that this is the single largest cause of tower failure at Amateur Radio stations.

Types of Towers

The most common variety of tower is the guyed tower made of stacked identical sections. The information in Fig. 2 is based on material from Kohn's catalog. Rohn calls for a maximum vertical separation between sets of guy wires of 35 feet (10.5 m). At A, the tower is 70 feet (21 m) high, and there are two sets of evenly spaced guy wires. At B, the tower is 80 feet (24.5 m) high, and there are three sets of evenly spaced guy wires. Exceeding the vertical spacing requirements could result in the tower buckling.

This may not seem like a reasonable

possibility unless you understand the functioning of the guy wires. The guy wires restrain the tower against the force of the wind and translate the lateral force of the wind into a downward compression that forces the tower down onto the base. Normally, the manufacturers specify the initial tension in the guy wires. This is another force that is translated into the downward compression on the tower. If there are not enough guys and if they are not properly spaced, a heavy gust of wind may turn out to be the "straw that breaks the camel's back." Fig. 2C is an overhead view of a guyed tower. Manufacturers usually call for equal angular spacing between radials. If it is necessary to deviate from this spacing, you would be well

advised to contact the engineering staff of the manufacturer or a civil engineer.

Some types of towers are not normally guyed — these are usually referred to as free-standing or self-supporting towers. The principles involved are the same regardless of the manufacturer's choice of names. The wind blowing against the side of the tower creates an overturning moment that would topple the tower if it were not for the anchoring at the base. Fig. 3 details the action and reaction involved. The tower is restrained by the base. As the wind blows against one side of the tower, the opposite side is compressed downward much as in the guyed-type setup. Because there are no guys to restrain the top, the side that the wind is blowing against is simultaneously being pulled up (uplift). The combination of the force of the wind and the structure is creating a moment that tends to pivot about a point in the base of the tower. The base of the guyed tower simply must hold the tower up, but the base of the free-standing tower must simultaneously hold one side of the tower up and the other side *down*! It should not be surprising that manufacturers often call for a great deal more concrete in the base of free-standing towers than they do in the base of guyed towers.

Fig. 4 shows two variations of another popular type of tower, the crank-up. In regular guyed or free-standing towers, each section is bolted atop the next lower section. The height of the tower is the sum of the heights of the sections (minus any overlap). Not so with the crank-up towers. The outer diameter of each section is smaller than the inner diameter of the next lower section. Instead of bolting together, the sections are attached with a complex set of cables and pulleys. The overall height of the tower is adjusted by

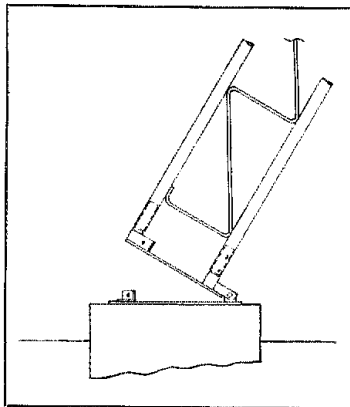

Fig. 5 — Fold-over or tilting base. There are several different variations of hinged sections permitting widely different types of installation. Great care should be exercised when raising or lowering a tilting tower.

using the pulleys and cables to "telescope" the sections together or apart.

Depending on the design, the manufacturer may or may not require guy wires. The primary advantage of the crank-up tower is that the owner must do the antenna work near the ground. A second advantage is that the tower can be kept retracted except during use, which reduces the guying needs (presumably, you would not try to extend the tower and use it during periods of high winds). The disadvantages include mechanical complexity and cost (usually). It is extremely dangerous to climb on a crank-up tower, even if it is extended only a small amount. Should the hoisting system fail, the inner sections could come crashing down like the blade of guillotine! (There are cases on record where amateurs have lost their lives by climbing extended crank-up towers on which the hoisting system failed.)

Another convenience feature that some towers have is a hinged section that permits the owner to fold over all or a portion of the tower. The primary benefit is in allowing antenna work to be done closer to ground level without the necessity of removing the antenna and lowering it. Fig. 5 shows a hinged base; of course, the hinged section can be designed for

portions of the tower other than the base. Also, a hinged feature can be added to a crank-up tower.

Several dealers and experts have commented to me that misuse of hinged sections during tower erections is a common problem among radio amateurs. Unfortunately, these episodes often end in accidents. If you do not have a good grasp of the fundamentals of physics, it might be wise to avoid hinged towers (or to consult an expert). It is often far easier (and safer) to erect a regular guyed tower or self-supporting tower with gin pole and climbing belt than it is to try to "walk up" an unwieldy hinged tower. Think seriously about hinged towers before you take the plunge!

The Base

Each manufacturer will provide his customers with detailed plans for properly constructing the base. Fig. 6 is an example of one such plan. This plan calls for a hole that is 3.5 x 3.5 x 6.0 feet (1 x 1 x 1.8 m). Steel reinforcement bars are lashed together and placed in the hole. The bars are positioned such that they will be completely embedded in the concrete, yet will not contact any metallic object in the base itself. This is done to minimize the possibility of a direct discharge path for

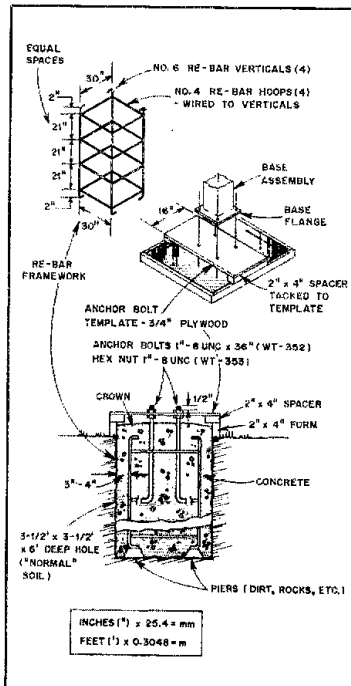

Fig. 6 — Plans for installing concrete base for Wilson ST-77B. Although the instructions and dimensions will vary from one tower to the next, this is representative of the type of concrete base specified by most manufacturers.

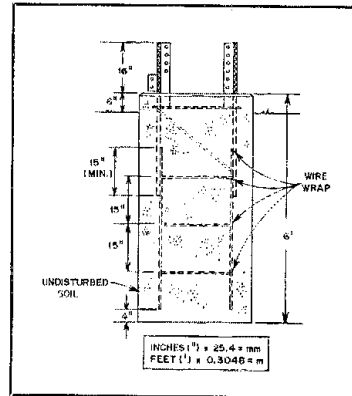

Fig. 7 — Another example of a concrete base (Tri-Ex LM-470).

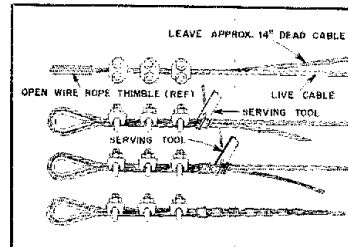

Fig. 8 — Traditional method for securing the end of a guy wire.

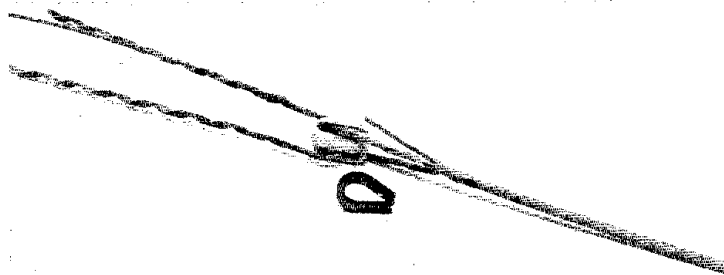

Fig. 9 — Alternative method for attaching guy wires using preformed guy grips. The grip on the right is completely assembled (the end of the guy wire was left extending from the grip for illustrative purposes). On the left, one side of the grip has been partially attached to the guy wire. In front, a thimble for use where a sharp bend might cause the guy wire or grip to break.

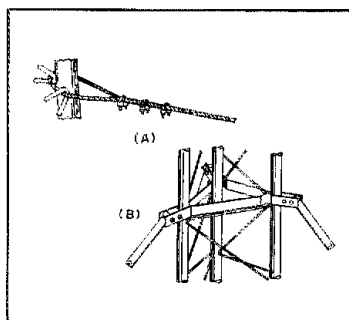

Fig. 10 — Two methods of attaching guy wires to tower. See text for discussion.

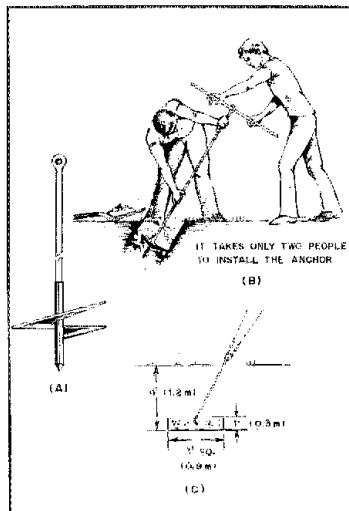

Fig. 11 — Two standard types of guy anchors. The earth screw shown at A is easy to install and widely available, but it may not be suitable for use with soil deviating from normal. The concrete anchor is more difficult to install properly, but it is suitable for use with a wide variety of soil conditions and will satisfy most building code requirements.

lightning through the base. Should such a discharge occur, the concrete base would likely explode and bring about the collapse of the tower.

A strong wooden form is constructed around the top of the hole. The hole and the wooden form are filled with concrete so that the resultant block will be 4 inches (102 mm) above grade. The anchor bolts are embedded in the concrete before it hardens. Usually it's easier to ensure that the base is level and properly aligned by attaching the mounting base and the first section of the tower to the concrete anchor bolts. Each manufacturer will provide specific detailed instructions for the proper mounting procedure. Fig. 7 provides a slightly different design for a tower base.

The one assumption so far is that you have normal soil. "Normal soil" is a mixture of clay, loam, sand and small rocks. A technical discussion is beyond the scope of this article, but you may want to adopt more conservative design parameters for your base (usually, more concrete) if your soil is sandy, swampy or extremely rocky. If you have any doubts about your soil, contact your local agricultural extension office and ask for a more technical description of your soil. Once you are armed with that information, contact the engineering department of your tower manufacturer or a civil engineer.

Attaching Guy Wires

In typical Amateur Radio installations a guy wire may experience "pulls" in excess of 1000 pounds (450 kg). Under such circumstances, you do not merely twist the wires together and expect them to hold. Fig. 8 depicts the traditional method for fixing the end of a piece of guy wire. A thimble is used to prevent the wire from breaking because of a sharp bend at the point of intersection. Three cable clamps follow to hold the wire securely. As a final backup measure, the individual strands of the free end are unraveled and wrapped around the guy wire. It is a lot of work, but it is necessary to ensure a firm connection.

Fig. 9 shows the use of a device that replaces the clamps and twisted strands of wire. These devices are known by various names — guy grips, preforms or deadends. Regardless of what you call them, they are far more convenient to use than are clamps. You must cut the guy wire to the proper length. The preform is installed into whatever the guy wire is being attached to (use a thimble, if needed). One side of the preform is then wrapped around the guy wire. The other side of the preform follows. The savings in time and trouble more than make up for the slightly higher cost.

Guy wire comes in different sizes, strengths and types. Typically, 3/16-inch (5-mm) EHS guy wire will be adequate for the moderate tower installation found at most Amateur Radio stations. Some amateurs prefer to use 5/32-inch (4-mm) "aircraft cable." Although this cable is somewhat more flexible than 3/16-inch EHS, it is only about 70% as strong. We recommend that you stay with standard guy wire and that you use nothing smaller than 3/16-inch (5-mm) EHS.

Fig. 10 shows two different methods for attaching guy wires to towers. At A, the guy wire is simply looped around the tower leg and terminated in the usual manner. At B, a "torque bracket" has been added. There probably isn't much difference in performance for wind forces that are tending to "push the tower over." If you happen to have more projected area (antennas, feed lines, etc.) on one side of the tower than the other, then the force of the wind will cause the tower to tend to twist into the ground. The torque bracket will be far more effective in resisting this twisting motion than will the simpler installation. The trade-off, of course, is in terms of initial cost.

There are two main types of anchors used for guy wires. Fig. 11A depicts an earth screw. It usually measures 4 to 6 feet (1.2 to 1.8 m) long. The screw blade at the bottom typically measures 6 to 8 inches (150 to 200 mm) in diameter. Fig. 11B illustrates two people installing the anchor. The shaft is tilted such that it will be in line with the guy wires. Earth screws are suitable for use in "normal" soil where permitted by local building codes.

The alternative to earth screws is the concrete block anchor. Fig. 11C shows the installation of this type of anchor; it is suitable for any soil condition, with the possible exception of a bed of lava rock! Consult the instructions from the manufacturer for the precise method of installation.

Turnbuckles and associated hardware are used to attach guy wires to anchors and to provide a convenient method of adjusting tension on the guy wires. Fig. 12A shows a turnbuckle of a single guy wire attached to the eye of the anchor. Turnbuckles are usually fitted with either two eyes or one eye, and one jaw. The

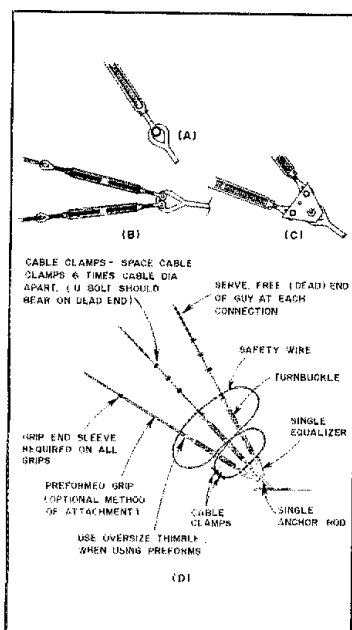

Fig. 12 — Variety of means available for attaching guy wires and turnbuckles to anchors.

eyes are the oval ends, while the jaws are U-shaped with a bolt through the tips. Fig. 12B depicts two turnbuckles attached to the eye of an anchor. The procedure for installation is to remove the bolt from the jaw, pass the jaw over the eye of the an-

Sources of Information

Data for this article was compiled from the literature made available by the following manufacturers. For more information and particular specifications, we suggest that you contact them or their dealers directly.

Aluma Tower
Box 2806
Vero Beach, FL 32960

Hy-Gain Division
Telex Communications, Inc.
9600 Adrich Ave., S.
Minneapolis, MN 55420

Tristao and Pratt Tower Company
P. O. Box 3715
Visalia, CA 93278

Wilson Systems, Inc.
4286 S. Polaris Ave.
Las Vegas, NV 89103

Heights Manufacturing Co.
4516 N. Van Dyke
Almont, MI 48003

Unarco-Rohn
P.O. Box 2000
Peoria, IL 61601

Tri-Ex Tower Corp.
7182 Rasmussen Ave.
Visalia, CA 93277

Universal Manufacturing Company
12357 E. 8 Mile Rd.
Warren, MI 48089

chor and reinstall the bolt through the jaw, through the eye of the anchor, and through the other side of the jaw. For two or more guys attached to one anchor, it is recommended that you install an equalizer plate (Fig. 12C). In addition to providing

a convenient point to attach the turnbuckles, the plate will pivot slightly and tend to equalize the tension on the guy wires. Once the installation is complete, a safety wire should be passed through the turnbuckles in a "figure-eight" fashion to prevent the turnbuckle from working loose

Summary

We've presented a short overview of towers and accessories. There is no way to answer all of your questions in an article of this scope. Hopefully, we have put you in a position to ask more (and better) questions of the person who has all the answers — the tower manufacturer. Before putting down the first dollar on your tower, do some research and make sure that your planned installation will be safe and will suit your needs. Please do not construe this article as an endorsement of any particular manufacturer, type of tower or type of accessory. We cannot and will not tell you which tower to buy. That is your decision. Make sure you don't wake up after a heavy storm and find that you've been impaled by your 20-meter reflector.

Notes

- 1. R. A. Ludwig, "Wind Force On A Yagi Antenna," *QST*, July 1974, p. 46.
- 2. J. J. Nagle, "How to Calculate Wind Loading on Towers and Antenna Structures," *Ham Radio*, August 1974, p. 16.
- 3. *Structural Standards for Steel Antenna Towers and Antenna Supporting Structures*, EIA Standard RS-222-C, Electronic Industries Association, March 1976, available from EIA, 2001 Eye St., N.W., Washington, DC 20006, price \$7.40.

Strays

TECHNICAL CORRESPONDENCE NEEDED

Technical Correspondence Editor Hall, KITD, is looking for letters that treat subjects of technical interest to *QST* readers. He is particularly interested in receiving letters dealing with solutions to technical problems, new design techniques and improvements to existing modern circuits. Constructive criticisms of published *QST* articles (technical aspects) are used in the column when appropriate and are welcomed. Our objective is to make the column interesting and useful by publishing material of high quality.

We are always happy to receive contributions for our Hints and Kinks column, too. If you have developed an innovation that might be of interest to other amateurs, please write a description of the gadget or concept and send it to Hints and Kinks Editor Leland, WIJEC, at ARRL Hq.

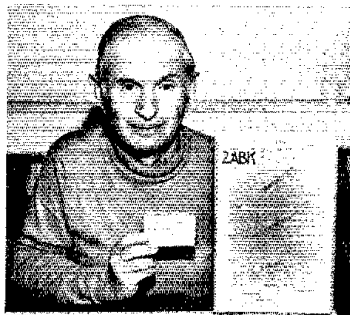

Talk about luck! While preparing to throw out some old books, Robert Hertzberg, K4JBI, unexpectedly found his original ham ticket folded up in one of them. Issued by the Department of Commerce, it was dated December 18, 1919. The former 2ABK has run the gamut from spark gap to sideband and is still an ardent operator and experimenter. (photo courtesy of K4JBI)

Technical Correspondence is the spot in *QST* to have your ideas or opinions aired. KITD is waiting to hear from you! — Doug DeMaw, W1FB

CLUB REBATES/FOREIGN FUNDS

Clubs wishing to take a commission for their treasury must send membership/subscriptions, new or renewal, to Hq. They must be sent by a club officer. Foreign remitters please write us promptly when sending money, stating the amount sent and clearly indicating what it covers. This will enable us to fill your request more quickly. — Marion Bayrer, ARRL Circulation Department

I would like to get in touch with . . .

- amateurs interested in forming a German language net. Harry Hinz, WB6LNZ, P. O. Box 546, Rio Vista, CA 94571.
- an amateur I worked in Panama in 1979. My log information is as follows: date, 7-29-79; time, 1645Z; call, KZ5KB; RST, his-569, mine-569; frequency, 21.195 MHz; name, Ken; QTH, Ft. Gulick, Dick MacWilliams, KA3CDQ, 4905 Ashford Dr., Upper Marlboro, MD 20870.
- other hams who would like to learn or practice foreign languages on the air. Gabe Gargiulo, WA1GFJ, 160 Elm St., North Haven, CT 06473.